

Mobile Cam (Model: MF69)

User Manual

Contents

1	Warning and precautions	5
1.1	Precautions	5
1.2	Aircraft safety	6
1.3	Precautions for medical Mobile Cams and facilities	6
1.4	General safety	7
1.5	Road safety	7
1.6	Vehicles equipped with an air bag	8
1.7	Third-party equipment	8
1.8	Radio frequency energy	8
2	Getting to know your Mobile Cam	11

2.1	Overview	11
2.2	Technical parameters.....	11
2.3	Environment requirement.....	12
2.4	Your Mobile Cam	12
2.5	Getting started	15
2.5.1	SIM/USIM card	15
2.5.2	T-FLASH.....	17
2.5.3	Battery	17
2.5.4	Charging the battery	18
2.5.5	Understanding indicators	19
2.6	Power on/off	20
2.7	Fixing the Mobile Cam onto the ceiling.....	20
3	White list.....	21
3.1	Mobile Cam's own phone number	22
3.2	Setting administrator (AD) number.....	22
3.3	Setting other user numbers.....	23
3.4	User entry.....	23
4	Mobile CAM controlled by 3G video phone	25

4.1	Camera adjustment.....	25
4.2	Adjusting speaker volume	26
5	Administrator main menu operation	27
5.1	Video phone main menu operation	27
5.5.1	Adding users	28
5.5.2	Deleting user	28
5.5.3	Changing PIN code	29
5.5.4	Changing administrator number.....	30
5.5.5	Video recording	30
5.2	SMS command operation	31
6	Infrared/daylight Operation Modes and Non-white List User Validation Function	37
7	Trouble Shooting.....	39

Thank you for using the Mobile Cam.

To guarantee the Mobile Cam is always in best condition, please read this manual carefully and keep for further use.

The pictures and contents in this manual are for your reference only. They might not be completely identical to your Mobile Cam.

1 Warning and precautions

1.1 Precautions

The Mobile Cam contains delicate electronic circuitry and battery systems. You should treat it with care and pay particular attention to the following points:

- ◆ Do not allow the Mobile Cam, battery or accessories to come into contact with liquids or moisture at any time. Do not immerse in any liquid.
- ◆ The Mobile Cam can't do the video call over 3 hours continuously. If the time is over 3 hours, it will shut off automatically.
- ◆ Do not place the Mobile Cam alongside computer disks, credit cards, travel cards or other magnetic media. The information contained on disks or cards may be affected by the Mobile Cam.
- ◆ Do not leave the Mobile Cam in places where the temperature could exceed 60°C – e.g. on a car's dashboard or a windowsill or behind glass in direct sunlight.
- ◆ Do not dispose the Mobile Cam in a fire. This equipment is fitted with an internal battery that can only be replaced by a qualified service engineer so used batteries must be safely disposed at a recycling point.
- ◆ Do not attempt to dismantle the Mobile Cam or any of its accessories.
- ◆ The Mobile Cam may become warm during normal use. The Mobile Cam may also become warm while the battery is being charged.

- ◆ Use a damp or anti-static cloth to clean the Mobile Cam. Do not use chemical or abrasive cleaners as these could damage the case.

1.2 Aircraft safety

- ◆ Onboard an aircraft, please turn off your Mobile Cam before take-off. In order to protect aircraft communications systems from interference, do not use the Mobile Cam while in flight. Using the Mobile Cam before take-off requires aircrew permission, according to safety regulations.
- ◆ Do not use the Mobile Cam on the ground at an airport without permission from ground staff.

1.3 Precautions for medical Mobile Cams and facilities

- ◆ When using your Mobile Cam near pacemakers, please: Always keep the Mobile Cam more than 8 inches (20 centimeters) from the pacemaker while the Mobile Cam is switched on.
- ◆ If you use any other personal medical device, please consult the device manufacturer to determine if it is adequately shielded from RF energy.
- ◆ If on premises with special demands, such as hospital or healthcare facilities, please pay attention to the restriction of the use of the Mobile Cams. Switch off your Mobile Cam if required.

1.4 General safety

- ◆ Keep the Mobile Cam out of the reach of small children. The Mobile Cam may cause injury if used as a toy.
- ◆ The operation of some medical electronic items, such as hearing aids and pacemakers, may be affected if the Mobile Cam is used in close proximity. Observe any related signs and manufacturer recommendations.

1.5 Road safety

- ◆ Switch off your Mobile Cam at refueling points, such as petrol stations, even if you are not refueling your own car.
- ◆ Do not store or carry flammable or explosive materials in the same compartment as a radio transmitter.
- ◆ Electronic vehicle systems, such as anti-lock brakes, speed control and fuel injection systems are not normally affected by radio transmissions. The manufacturer of such equipment can advise if it is adequately shielded from radio transmissions. If you suspect vehicle problems caused by radio transmissions, consult your dealer and do not switch on the Mobile Cam until it has been checked by qualified and approved installers.

1.6 Vehicles equipped with an air bag

- ◆ An air bag inflates with great force. Do not place objects, including installed or portable wireless equipment in the area above the air bag or in the air bag deployment area. If in-vehicle wireless equipment is improperly installed and the air bag inflates, serious injury could result.

1.7 Third-party equipment

- ◆ The use of third-party equipment, cables or accessories, not provided or authorized by Hwawo Technologies Co, .Ltd, may invalidate the warranty of your Mobile Cam and also adversely affect the Mobile Cam's operation.

1.8 Radio frequency energy

- ◆ Your Mobile Cam is a low-power radio transmitter and receiver. When it is switched on, it intermittently receives and transmits radio frequency (RF) energy (radio waves). The system that handles the call also controls the power level at which the Mobile Cam transmits.
- ◆ The antenna(s) used for this transmitter must be installed to provide a separation distance of at least 20cm from all persons.
- ◆ This device complies with part 15 of the FCC Rules. Operation is subject to the following two conditions :(1) This device may not cause harmful interference,

and(2) this device must accept any interference received, including interference that may cause undesired operation.

- ◆ NOTE: The phone has been tested and found to comply with the limits for a Class B digital device, pursuant to part 15 of the FCC Rules. These limits are designed to provide reasonable protection against harmful interference in a residential installation.

The phone generates uses and can radiate radio frequency energy and, if not installed and used in accordance with the instructions, may cause harmful interference to radio communications. However, there is no guarantee that interference will not occur in a particular installation. If the phone does cause harmful interference to radio or television reception, which can be determined by turning the equipment off and on, the user is encouraged to try to correct the interference by one or more of the following measures:

- Reorient or relocate the receiving antenna.
- Increase the separation between the equipment and receiver.

MF69

—Connect the equipment into an outlet on a circuit different from that to which the receiver is connected.

—Consult the dealer or an experienced radio/ TV technician for help.

◆ We, declared that the product is installed with battery separately in the box. The FCC ID label is placed on the mobile cam clearly visible to all persons at the time of purchase.

2 Getting to know your Mobile Cam

2.1 Overview

Empowered by the latest 3G technology, Mobile Cam is capable of receiving video phone calls automatically. Users can dial the Mobile Cam from any WCDMA handset supporting video phone calls, and view the picture with sound captured by the Mobile Cam anytime, anywhere. The Mobile Cam supports video call, but doesn't support voice call.

2.2 Technical parameters

Type	Mobile Cam (Model: M69)
Dimensions (WxLxH)	156mmX129mmx111.5mm
Weight	263g (with integrated battery)
Camera	0.3 megapixel (solar/infrared dual mode)

Battery

Continuous standby time	120-200 hours
Recording time (in sunlight environment)	7-12 hours
Recording time (in infrared environment)	3-5 hours

Video communication time (in sunlight environment) 2-3 hours
Video communication time (in infrared environment) 1.6-2.6 hours
Charging time 5 hours

2.3 Environment requirement

The Mobile Cam can be used indoors or half-outdoors – e.g. inside an automobile.

Environment parameter details are as follow:

Working temperature range: $-10^{\circ}\text{C}\sim 45^{\circ}\text{C}$

Relative humidity: 5%~95% (without dew)

Power supply: 220V supply, integrated spare battery

This mobile camera is only used in WCDMA network.

2.4 Your Mobile Cam

Front view of your mobile cam

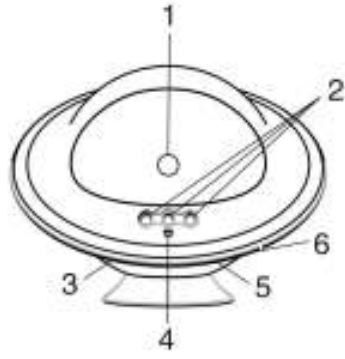

1. Camera 2. Infrared spotlight 3. Power indicator
4. Infrared sensor 5. Signal indicator 6. MIC

Camera: The camera can rotate upward at an angle up to about 40 degrees, downward at an angle up to about 5 degrees, and left and right at an angle up to about 45 degrees.

Power indicator: Indicates the level of charge in your battery. There are five colors: white, blue, cyan, green and red.

Signal indicator: Indicates local network signal strength. There are two colors: Red and

Green.

Infrared spotlight: The infrared spotlight will start up automatically when the light intensity is lower than 20 LUX.

Infrared sensor: This senses daylight intensity. When the light intensity is higher than 20 LUX, the infrared spotlight will be closed and the Mobile Cam will switch to daylight working style.

MIC: An integrated microphone dedicated to receive local audio signal.

Back view of your mobile cam

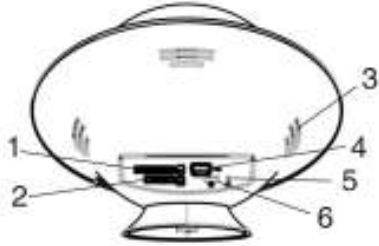

1. SIM/USIM card slot 2. T-Flash card slot 3. Speaker

4. Charger Connector 5. Reset 6. Power

On the back of the unit, there are 3 slots: SIM/USIM, T-Flash and charger. Please refer to 1.5.1, 1.5.2 and 1.5.4 respectively for details. There are also 2 buttons:

- **POWER:** Power on/off.
- **RESET:** Restart the system. White list and password will not be affected.

2.5 Getting started

Make sure you follow the operation procedure before using the Mobile Cam.

- Insert a 3G SIM/USIM card.
- The battery should be fully charged before you use the Mobile Cam, otherwise the Mobile Cam may not function correctly.
- Set date and time. See details in Section 4.2.

2.5.1 SIM/USIM card

Be sure to insert a 3G SIM/USIM card before you use the Mobile Cam.

Note:

- ◆ A SIM/USIM card set with PIN code cannot be used normally in the Mobile Cam. You need to use another mobile phone to unlock the PIN code of the SIM/USIM card before using it in the Mobile Cam.

- ◆ Make sure to disconnect the charger and switch off your Mobile Cam before inserting or removing your SIM/USIM card.
- ◆ Inserting SIM/USIM card.
 1. Make sure your charger is disconnected, then press and hold down the power key until the Mobile Cam is powered off.
 2. Pull out the plastic plug covering the SIM/USIM card slot.
 3. Insert the SIM/USIM card, with the metal surface facing downward and the bevel end inward, until you hear “a cracking sound”.
 4. Insert the plastic plug back into the SIM/USIM card slot to keep it from dust.
- ◆ Removing SIM/USIM card
 1. Make sure your charger is disconnected, then press and hold down the power key until the Mobile Cam is powered off.
 2. Pull out the plastic plug covering the SIM/USIM card slot.
 3. Press the SIM/USIM card until you hear “a cracking sound”, when the SIM/USIM card will pop up to be pulled out.
 4. Insert the plastic plug back into the SIM/USIM card slot to keep it from dust.

Note:

Don't touch the metal surface of the SIM/USIM card in case information in the card is lost or destroyed. Do not bend or scratch your SIM/USIM card. Keep the card away from electricity and magnetism.

Make sure to disconnect the power source from your Mobile Cam before inserting and removing your SIM/USIM card.

2.5.2 T-FLASH

The T-FLASH card is used to save a recorded video file. The process of inserting and removing the T-flash card is the same as the SIM/USIM card.

Note:

- ◆ When the T-FLASH card is inserted, the metallic surface is upward, which is different from how to insert the SIM/USIM card.

2.5.3 Battery

Your Mobile Cam is equipped with a Lithium ion battery. You do not need to purchase a new one. You should, however, charge the battery after purchase, as the stored charge may be insufficient to power on the Mobile Cam. The battery can be recharged at any time and will not affect operation.

The Mobile Cam will be powered off automatically when the power is low. Battery performance will deteriorate as the battery's lifecycle draws to an end. When this happens, you should contact the manufacturer/repair centre to purchase a replacement.

Do not disassemble the Mobile Cam to change the battery.

2.5.4 Charging the battery

Please use only the provided charger to charge the Mobile Cam. In the charging process, the POWER indicator is blue. When the battery is fully charged, the POWER indicator will turn from blue to green.

1. Connect the adapter to the adapter connector.
2. Plug the other end of the charger into an appropriate electrical outlet.
3. When charging is complete, disconnect the adapter from the electrical outlet and remove from the adapter connector.

Note:

- ◆ Please stop charging if abnormal heat, odor or deformation is detected.
- ◆ Charging time may be longer when the Mobile Cam is powered on.
- ◆ Use only our own adapter with this Mobile Cam. Using unauthorized chargers may be dangerous and may violate the authorization and warranty rules of the Mobile Cam.
- ◆ The phone's talk time and monitoring time are based on ideal working environments. In practice, the working time varies according to different network conditions, environments and modes.
- ◆ The power indicator light will blink fast in red when the battery is exhausted. Please charge the battery immediately.

2.5.5 Understanding indicators

The Mobile Cam has two indicators on the front panel – one for the level of charge in your battery and the other for local network signal strength

Signal indicator: Indicates local network signal strength.

Detail	Description
Red (flash)	No network strength or low network strength
Green (flash)	Normal network strength

Power indicator: Indicates the level of charge in your battery.

Detail	Description
White (normal)	Power on
Cyan (normal)	No SIM/USIM card or invalid SIM/USIM card
Blue (normal)	Charging when powered off
Blue (flash)	Charging when powered on
Green (normal)	Charging finished when powered off
Green (flash)	Sufficient power
Red (flash)	Low power (less than 15% of the total battery level)
Red (flash quickly)	Weak power (less than 10% of the total battery level and no charging)

Note:

Flash means the indicator blinks every 5 seconds. Flash quickly means the indicator blinks every 2 seconds.

Infrared spotlight: If the switch of infrared mode is set "on" (please refer to Section 4.2), when light is weak (less than 20 LUX), the Mobile Cam will shut down daylight mode and start infrared mode automatically. At that time, Infrared spotlight will be turned on to provide illumination.

2.6 Power on/off

Power on

- 1 Ensure that your SIM/USIM card has been inserted and the battery is charged.
- 2 Press and hold down **POWER** button until power indicator turns white. The power on process is finished when the color of power indicator turns from white to other colors.

Power off

Press and hold down the **POWER** button (hold for about 3 seconds) until the light is off.

2.7 Fixing the Mobile Cam onto the ceiling

The following pictures show how to fix the Mobile Cam onto the ceiling:

1. You can use three screws (screw 1) to connect the bracket and body of the Mobile Cam firmly.

2. Then you can use two screws (screw 2) to fix the bracket firmly onto the ceiling.

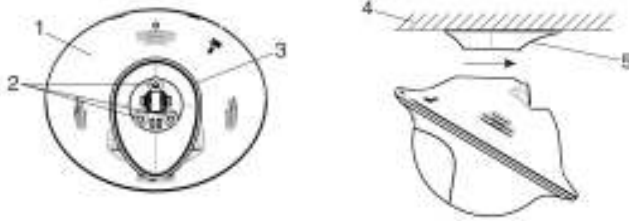

1. Body 2.Screw 3/5.Bracket 4. Ceiling

3 White list

The white list contains only legitimate user numbers. The maximum number of records that can be saved in the white list is 20.

3.1 Mobile Cam's own phone number

Insert a valid SIM/USIM card. The SIM/USIM card number is also the Mobile Cam number. If the PIN code of the SIM/USIM card is locked, you should unlock the code by using in another mobile phone. Otherwise, that card cannot be used by Mobile Cam. Also, Mobile Cam cannot operate if the SIM/USIM card is invalid.

3.2 Setting administrator (AD) number

White list default is blank for a new Mobile Cam. The first legitimate user to call the Mobile Cam becomes the AD.

First, confirm the AD phone number and make a video call to the Mobile Cam using this number.

Next, after the call connects, AD will be prompted to enter user PIN code (**the default PIN code is 0000**) and end by pressing * key. If AD inputs the PIN code correctly, AD's handset can make a video call with the Mobile Cam. In the default situation, the Mobile Cam will sound a beep to notify AD that the AD number is set (It can be set by SMS command that whether the beep switch is on or off). After 3 consecutive incorrect PIN code entries, or if you have not been able to enter the PIN code within 60 seconds, the Mobile Cam will be disconnected automatically. If the PIN code is correct, AD will enter the video call interface.

Note:

Once you set the AD number on the Mobile Cam, you can check or revise the time by SMS. For details, please refer to the section on SMS command operation.

The AD number should be set in WCDMA network, using a local number. An attempt to set the number from outside local network using a mobile roaming or IDD service will result in an invalid number being saved in the white list.

3.3 Setting other user numbers

In addition to the AD, other phone numbers will be added to the white list (maximum 20 numbers in the white list, except the AD) when making a video call to the Mobile Cam with a correct PIN code entered.

First, make a video call to the Mobile Cam using a non-AD number.

When the call connects, the screen will prompt you to enter a PIN code. A “beep” sound from the Mobile Cam indicates that the video call has been successfully connected. If you make 3 consecutive incorrect PIN code entries, or have not been able to enter the PIN code within 60 seconds, the Mobile Cam will be disconnected automatically. If the PIN code is valid, the user will enter the video call interface.

The AD can also set the other user number via the video phone menu or SMS commands (see Section 4.1, 4.2). AD can also set validation for non-white list users (see Chapter 5).

3.4 User entry

White list user: Phone numbers added to white list (including AD number). The white list

MF69

user can dial the mobile camera without the need to input a PIN (this function depends on the SMS setting).

Non-white list user: If the white list is not full, and the non-white list user dials up the Mobile Cam using the correct PIN code, the caller's phone number will be added to the white list automatically. If the number of phone numbers in the white list has reached 20, the Mobile Cam will refuse to accept non-white list users (this function depends on AD settings).

4 Mobile CAM controlled by 3G video phone

Only the AD can use SMS to configure the Mobile Cam. Other white list users (including the AD) can control the Mobile Cam by video phone. See operating features below:

4.1 Camera adjustment

White list users can adjust the angle, brightness and zoom of the camera. Rotate the camera right/ left 45°, upward 40°, downward 5° and control 3X digital zoom.

Press "2" key to rotate the camera upward

Press "4" key to rotate the camera to the left

Press "6" key to rotate the camera to the right

Press "8" key to rotate the camera downward

Press "5" key to reverse the picture to 180 degrees

Press "1" key to zoom-out

Press "3" key to zoom-in

Press "7" key to reduce camera brightness.

Press "9" key to increase camera brightness.

Note: The key operations only function during the video call process.

4.2 Adjusting speaker volume

In the process of a video call, you can adjust the volume by pressing “#” key and “*” key. There are 5 levels of volume: silent, low, normal, high and maximum. Press “#” key to increase volume. Press “*” key to decrease volume.

Note: Speaker will be set to silence by default when video call is connected.

5 Administrator main menu operation

The first person to dial the Mobile Cam successfully becomes the administrator (AD). The administrator can operate the Mobile Cam by video phone menu and SMS command.

5.1 Video phone main menu operation

After a video call is connected, the administrator should press "0" key to enter the submenu. Follow the instructions to add users, delete users, and change PIN code and administrator number and record video.



Note: Screens are for reference only. If a discrepancy exists between the actual screen and above photo, the actual screen will be deemed to be correct.

5.5.1 Adding users



In main menu, press the “1” key to enter the **Add User** interface. Enter the phone number of the new user, and end by pressing “*” key. Press “*” key again to confirm the operation, press “#” key to cancel the operation and go back to main menu.

5.5.2 Deleting user



In main menu, press “2” key to enter the **Delete User** interface. Press “*” key for paging down. Select the serial number before the phone number you want to delete. Press “*” key to confirm the deletion, press “#” key to cancel the operation and go back to main menu.

5.5.3 Changing PIN code

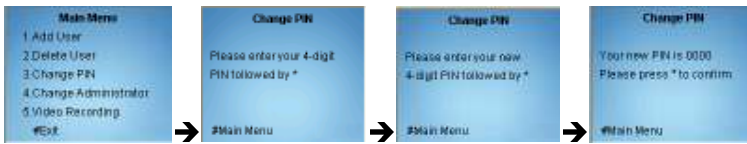

In main menu, press "3" key to enter the **Change PIN** interface. Enter the current PIN code and end with "*"key, then enter the new code and end with "*"key. Press "*" key to confirm the input.

If you input the wrong number, press "#" key to go back to main menu.



5.5.4 Changing administrator number



In main menu, press “4” key to enter the **Administrator Change** interface. Enter the new administrator phone number and end by “*” key. Press “#” key to cancel operation and go back to main menu.

5.5.5 Video recording



In main menu, press “5” key to enter the **Video recording** interface. You will see free T-flash space and recording time available. After you enter the period you want to record, the Mobile Cam will end the current video call and enter video-recording mode.

The recorded file will be saved in the T-Flash card and will be named `yyyymmddhhmm_xx.3gp` (yyyymmddhhmm represents year, month, day, hour and minute. The year contains 4 digits, while the others all contain 2 digits. For example, 200605011230 stands for 12:30 May 1, 2006. XX stands for the serial number, such as 00, 01 and so on).

Maximum recorded video file size is 3 hours. If the recorded time is longer than 3 hours, there will be several files. Recording time depends on memory card storage and varies according to actual situation.

An incoming video call during the recording will cause the Mobile Cam to stop recording and send an SMS to the administrator and then continue the incoming call.

The administrator will receive an SMS sent by Mobile Cam when the video recording is finished, when the memory is full or when the video recording fails under the other situations.

Note:

Recording is not possible if no T-flash card is inserted into the Mobile Cam.

5.2 SMS command operation

The administrator can also set Mobile Cam parameters by sending an SMS command, e.g. the administrator can send SMS to the Mobile Cam to modify user PIN code modify administrator and add/delete a user.

Some functions can only be operated by SMS command – e.g. time setting and BEEP

switch setting.

Command	SMS COMMAND
Adding a new user	#adduser*[number]#[pin]#
Deleting a user	#deluser*[number]#[pin]#
Modifying user PIN code	#modpin*[newpin]#[pin]#
Modifying administrator number	#modad*[oldnumber]*[newnumber]#[pin]#
Setting the language	#setlanguage*en ar es ch tw #[pin]# The default is English. en—English ar—Arabic es--Spanish ch---Simplified Chinese tw---Traditional Chinese
Getting white name list	#getwl#[pin]#
BEEP on/off when video call is connected	#beep*on off#[pin]# Default is "on"
Help	help A list of available SMS commands will be sent to the Administrator, through multiple SMS messages.

Setting time	#settime*[yyyymmddhhmm]#[pin]#
Getting time	#gettime#[pin]#
Setting the switch to control whether user needs to input PIN code every time	#pin*on off#[pin]# The default is "off". If the switch is set as "on", the caller has to input the PIN code every time, whether his number is in the white list or not. If the switch is set as "off" and the caller's number is in the white list, he does not need to input the PIN code.
Setting the switch of infrared mode	#nightmode*on off#[pin]# The default is "on".
Setting the switch of the led indicators	#led*on off#[pin]# The default is "on".
Setting the validation of non-white list user	#owner*on off#[pin]# The default is "on". If the switch is set as "on", the Mobile Cam will prompt user to input his calling number in the following situations, so as to decide whether the video call is allowed: 1. the incoming call doesn't carry any number (may be

	<p>the caller is roaming or the caller disables the phone to send its number), or</p> <ol style="list-style-type: none"> 2. the incoming call's number exceed 20 digits, or 3. the white list reaches its limit and the incoming call's number isn't in the white list. <p>If the entered number is in the white list, then the user will be further prompted for the PIN and video call will proceed if the PIN is correct. If the number is not in the white list or the PIN has been input incorrectly 3 times, the call will be disconnected.</p> <p>If the switch is set as "off". the Mobile Cam won't allow the video call in the following situations:</p> <ol style="list-style-type: none"> 1. the incoming call doesn't carry its number (may be the caller is roaming or the caller disables the phone to send its number), or 2. the incoming call's number exceed 20 digits, or 3. the incoming call's number isn't in the white list and the white list reaches its limit
Get phone status	#getstatus#[pin]#
Set access mode	#accessmode*wl fr#[PIN]#

	<p>wl: White list access mode is the default mode (The user connecting the monitor will be saved in the White list. Your role will be authenticated before you access the monitor)</p> <p>fr: Free access mode (you can connect with the monitor freely without authentication. There is no White list in this access mode and any user can access the monitor.)</p>
Set power ring volume level	#powerringvolume*[x]#[PIN] x=0,1,2,3
Clear the White list	#clearwl#[PIN]#

Note:

1) SMS commands can only be sent by the administrator's mobile phone number. The SMS will not be recognized by the Mobile Cam if a command is sent from another mobile phone number.

2) All commands can be in lower-case or upper-case letters

3) Command explanation

[number]: Indicates a valid mobile phone number. The phone number's maximum length is

MF69

20 digits. (“+” will be ignored).

[pin]: Indicates user PIN code. It should be in 4 digits.

[newpin]: Indicates new user PIN code. It should be in 4 digits.

[oldnumber]: Indicates old administrator number

[newnumber]: Indicates new administrator number

|: Indicates “or”

- [yyyymmddhhmm]: Indicates year, month, day, hour, minute. For example: 12:30, May 1, 2006 is displayed as 200605011230.

Note:

Please use a 3G mobile phone to make sure the SMS center number in your SIM/USIM card is correct.

6 Infrared/daylight Operation Modes and Non-white

List User Validation Function

The Mobile Cam has two operation modes – daylight mode and infrared mode. In the infrared mode, it turns on infrared spotlight. If the switch of infrared mode is on (please refer to Section 4.2) and the light is weak (less than 20 LUX), the Mobile Cam will shut down daylight mode and start infrared mode automatically. Vice versa, when light is bright (more than 20 LUX), the Mobile Cam will switch from infrared mode to daylight mode. If the switch of infrared mode is off, the Mobile Cam will always run in the daylight mode.

Special video call processing modes under the non-white list user validation function:

If there is an incoming call whose number isn't displayed (The caller may be roaming or the caller switched off the function of indicating calling number), or whose number exceeds 20 digits, or the white list is full and the number isn't in the white list, the Mobile Cam will validate the user as follow:

- 1) When the switch of the validation of non-white list user is set as "on", the Mobile Cam will prompt user to input calling number. If the number is already in the white list, the user will be further prompted to input the PIN. After entering the correct PIN code, the video call will be connected. If the number is not in the white list or 3 consecutive incorrect PIN codes have been entered, the call will be terminated.

2) When the switch of the validation of non-white list user is set as "off". the Mobile Cam won't allow the video call.

Note: please see Section 2.4 for normal white list operation.

Rules for number verification:

- If an incoming call number is more than 8 digits, on the last 8 digits will be verified.
- If an incoming call number is less than 8 digits, the whole number will be verified.
- "+" symbol is not included for verification (IDD call in number may have "+" symbol).

7 Trouble Shooting

When you encounter problems in the operation of MF69, please look up the trouble shooting before you contact our technical support.

Q: Why can't M69 be powered on?

A: Please check the color of the power indicator if the power indicator isn't lightened or there is no power-on music, please charge the mobile cam. If the color of power indicator is Cyan, please check if the USIM card is valid and is not locked (You can try the USIM card in a handset. If it promotes you to input PIN code when you power on the handset, please set the switch of the PIN code off) Please insert the USIM card into the USIM card slot and press Power key to power on the mobile cam, after you confirm the USIM card is valid.

Q: Why can't I call in video call?

A: Please check the color of the signal indicator. If the signal indicator is not lightened, the mobile cam hasn't powered on normally. Please press Power key to power on the mobile cam. If the signal indicator is red (flash), there is no 3G network available or the signal of the 3G network is very weak. If the signal indicator is yellow (flash), the mobile cam can work properly. If you can't dial in video call, please check whether your handset is roaming or the phone number is concealed. The video call not carrying the number can't enter the mobile cam successfully for the safety.

Q: Why isn't the communication stable or can't I dial video call in some places?

A: The communication can be unstable or the video call can't be dialed when you are in some places where the signal is unstable. Please go to some other places to try again or contact your service provider.

Q: Why isn't there any notifying tone when dial up a video call?

A: There are relative settings in the mobile cam. You can set the switch of the notifying tone on/off by send SMS through the AD number.

Q: Why is there echo when using the mobile cam in some places?

A: It's called "echo phenomenon". It happens when the volume is too big or your handset is too close to the mobile cam.

Q: Why can't the handset display the main menu and control the mobile cam by sending SMS?

A: It is because your number is not the AD number. Only the AD number can set the parameters of the mobile cam for the safety.

Q: Why can't the video call be dialed up when the mobile cam works properly?

A: Please check whether your handset is roaming or conceal the number. No video calls can be dialed up when the mobile cam can't recognize the number. If you receive the prompt SMS "The white list reaches its limit, you can't be connected." At this time, you can delete some of the numbers in the white list through the AD number.

Q: If there is an unexpected situation when the mobile cam doesn't work, what shall I do?

A: You can press Power key to restart the mobile cam.

Q: What shall I do if I forget the password or the ad number?

A: Please send your mobile cam to the retailer or the appointed maintenance place to reset the password.

Declaration of RoHS

Compliance

To minimize the environmental impact and take more responsibility to the earth we live, this document shall serve as formal declaration that the MF69 are in compliance with the Directive 2002/95/EC of the European Parliament - RoHS (Restriction of Hazardous Substances) with respect to the following substances:

- (1) Lead (Pb)
- (2) Mercury (Hg)
- (3) Cadmium (Cd)
- (4) Hexavalent Chromium (Cr (VI))
- (5) Polybrominated biphenyls (PBB's)
- (6) Polybrominated diphenyl ethers (PBDE's)

Compliance is evidenced by written declaration from our suppliers, assuring that any potential trace contamination levels of the substances listed above are below the maximum level set by EU 2002/95/EC, or are exempt due to their application.

The MF69 Mobile Cam meets the requirements of EU 2002/95/EC; however, some assemblies are customized to client specifications. Addition of specialized, customer-specified materials or processes which do not meet the requirements of EU 2002/95/EC may negate RoHS compliance of the assembly. To guarantee compliance of the assembly, the need for compliant product must be communicated to CCTUNG Industrial Co., Ltd in written form.

This declaration is issued based on our current level of knowledge. Since conditions of use are outside our control, CCTUNG Industrial Co., Ltd makes no warranties, express or implied, and assumes no liability in connection with the use of this information.